

TYPE 12 NEMA CLAMP ENCLOSURES

3-3



Industry Standards
UL 508A, Type 2, 12, 13
NEMA Type 2, 12, 13



UL File E235575

TYPE 12 ENCLOSURES

Application:

Designed to enclose electrical, electronic controls, instruments and components and provide protection from falling dirt, dust, oil and water.

Construction:

- Steel fabricated doors and enclosure.
- Smooth, continuously welded seams without knockouts, cutouts, or holes.
- Welded brackets provided for enclosure mounting.
- Continuous hinged door is removable by pulling hinge pin.
- Door is secured with NEMA style clamps.
- Provisions for padlocking.
- Door is sealed with closed cell, oil resistant gasket.
- Print pocket is provided.
- Collar studs are provided for mounting optional inner panels.
- Grounding studs are provided.

Finish:

- ANSI 61 gray powder coating inside and out over phosphatized surfaces. Optional panels are powder coated white.

Accessories:

- Back Panels (see reference chart, pg. 6-3)

Options:

- Custom sizes and colors available. Please call for details.

Enclosure Catalog Number	Enclosure Size H x W x D	X	Back Panel Catalog Number	Back Panel Size A x B
N12N-181606	18.00" x 16.00" x 6.00"	6.070"	PSN-1816	15.00" x 13.00"
N12N-202008	20.00" x 20.00" x 8.00"	8.070"	PSN-2020	17.00" x 17.00"
N12N-242006	24.00" x 20.00" x 6.00"	6.070"	PSN-2420	21.00" x 17.00"
N12N-242008	24.00" x 20.00" x 8.00"	8.070"	PSN-2420	21.00" x 17.00"
N12N-242406	24.00" x 24.00" x 6.00"	6.070"	PSN-2424	21.00" x 21.00"
N12N-242408	24.00" x 24.00" x 8.00"	8.070"	PSN-2424	21.00" x 21.00"
N12N-302410	30.00" x 24.00" x 10.00"	10.070"	PSN-3024	27.00" x 21.00"
N12N-362406	36.00" x 24.00" x 6.00"	6.070"	PSN-3624	33.00" x 21.00"
N12N-362408	36.00" x 24.00" x 8.00"	8.070"	PSN-3624	33.00" x 21.00"
N12N-363010	36.00" x 30.00" x 10.00"	10.070"	PSN-3630	33.00" x 27.00"
N12N-423610	42.00" x 36.00" x 10.00"	10.070"	PSN-4236	39.00" x 33.00"
N12N-483610	48.00" x 36.00" x 10.00"	10.070"	PSN-4836	45.00" x 33.00"



211 INDUSTRIAL COURT
WABASHA, MN 55981

*DATA SUBJECT TO CHANGE WITHOUT NOTICE

Phone: (651) 565-3395
Fax: (651) 565-2787
E-mail: info@thomasindustriesinc.com
www.thomasindustriesinc.com

TYPE 12 NEMA CLAMP ENCLOSURES

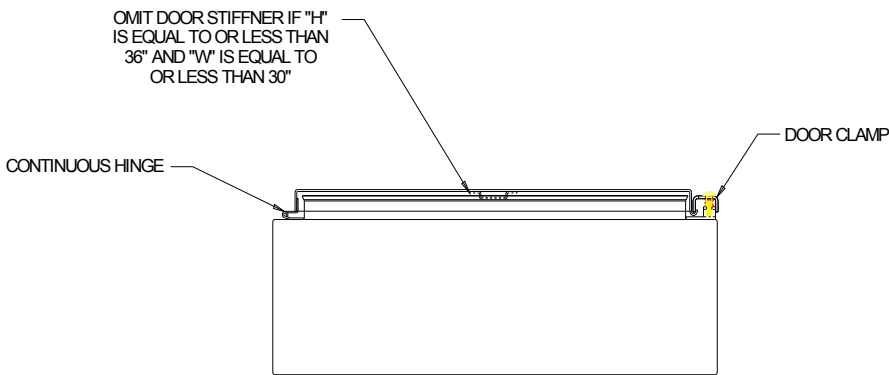
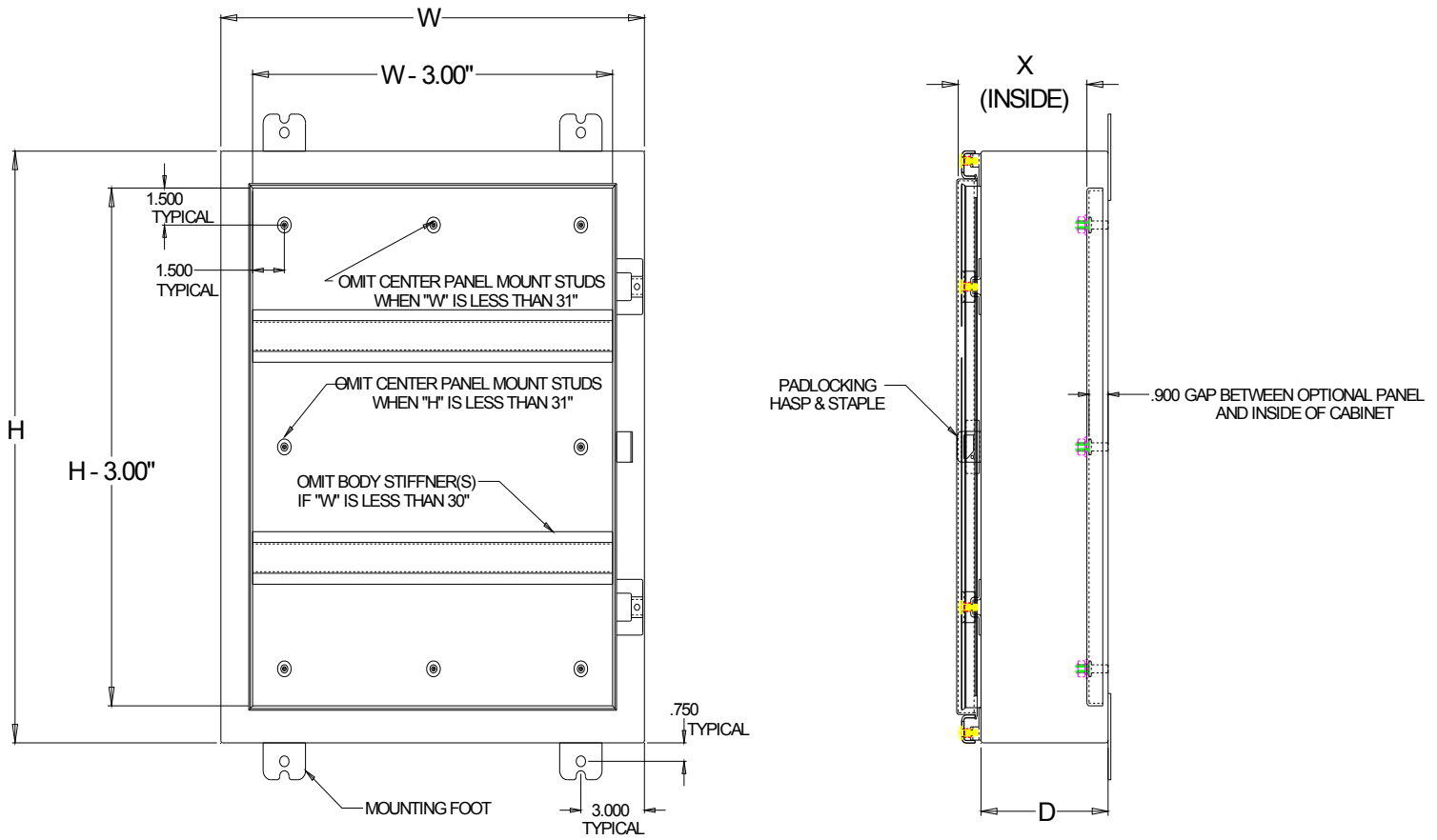

211 INDUSTRIAL COURT
WABASHA, MN 55981

Phone: (651) 565-3395
 Fax: (651) 565-2787
 E-mail: info@thomasindustriesinc.com
www.thomasindustriesinc.com